

Managed MicroNode™ RFoG ONUs

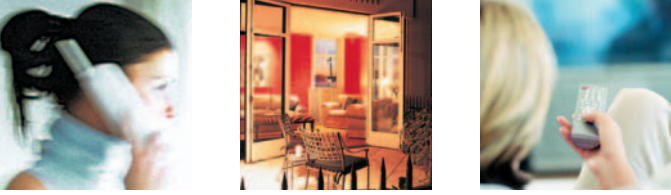

The **Alloptic Managed MicroNode™ R-ONU** enhances the benefits and efficiencies delivered by RFoG architectures by adding management capabilities to Alloptic's award-winning MicroNode product line. Management includes not only parametric monitoring but operational access as well, providing service control, key network performance data, and incremental cost savings.

Even though the R-ONU is the critical optical enabler in an RFoG architecture, it has traditionally been an unmanaged device. With the Alloptic Managed MicroNode RFoG ONU, service providers now have the ability to cost-effectively monitor ONU operating parameters as well as remotely enable and disable service. With this control, service connects and disconnects are achieved without a service dispatch or truck roll, significantly decreasing operational costs and decreasing theft-of-service losses.

Managing an RFoG ONU is a valuable tool in many ways. It is important for troubleshooting and also to support the growing desire to manage every element in the network. Remote service control saves the tangible cost of a truck roll and frees that truck and technician to focus on higher value activities. Maximizing access to network status information not only facilitates ongoing operating improvements but also leads to improved customer satisfaction and reduced churn.

Along with management and control, Alloptic's Managed MicroNode offers all the advantages of RFoG technology. It extends fiber deeper into the network – to the subscriber's location from a headend or hub – while continuing to use the embedded HFC/DOCSIS infrastructure. At the subscriber's premises, a low-cost MicroNode RFoG ONU connects the fiber to the existing in-building wiring, using the same cable modems, set top boxes, and other CPE. At the headend, existing infrastructure is leveraged as well. The same laser transmitters, CMTS, QAM modulators, and EDFAs continue to be used along with the current provisioning, operating and billing systems. An RFoG architecture offers a service provider savings in both CAPEX and OPEX.

The Alloptic Managed MicroNode™ RFoG ONU family of products delivers all the benefits of Alloptic's industry-leading RFoG solution along with remote monitoring and control capabilities.



MicroNode 1100



MicroNode 1120



MicroNode 1150



MicroNode Controller

Managed MicroNode™ RFoG ONUs

Benefits

- Remote enable/disable – No service dispatch for service connects, disconnects or re-connects
- Monitor electrical, optical and environmental performance remotely
- Communications channel is compatible with existing HFC and RFoG infrastructures to simplify deployment without using occupied spectrum
- Flexible access via a master controller with SNMP, telnet or a browser-based GUI
- Interfaces to OSS/BSS and higher-order management systems
- Unrivalled performance of Alloptic's industry-leading MicroNode RFoG ONUs
- Superior optical and RF performance characteristics
- Industry leading burst mode characteristics for optimizing and maximizing return path transmission and bandwidth availability.

Key Capabilities

A key new feature of Managed MicroNode R-ONUs is the ability to remotely control the delivery of service to the customer premise:

- RF on/off
- Optical transmit on/off (return path)

The Managed MicroNode R-ONUs also allow access to a variety of monitored performance parameters:

- Optical input power (downstream)
- RF output power (downstream)
- RF input power (return path)
- Temperature
- External contact closure input for alarms

Ordering information

Part #	Description
MNTH1101	Managed MicroNode RFoG ONU (42MHz/1310nm RP)
MNTH1104	Managed MicroNode RFoG ONU (65MHz/1310nm RP)
MNTH1126	Managed MicroNode RFoG ONU (42MHz/1610nm RP)
MNTH1127	Managed MicroNode RFoG ONU (65MHz/1610nm RP)
MNTH1132	Managed MicroNode RFoG ONU (65MHz/1550nm RP)
MNTH1133	Managed MicroNode RFoG ONU (42MHz/1550nm RP)
MNTH1156	Managed MicroNode RFoG ONU (1550/1610 65)
MNTH1157	Managed MicroNode RFoG ONU (1550/1610 88)
MNTH1556	MDU MicroNode RFoG ONU (42MHz/1610nm RP)
MNTH1557	MDU MicroNode RFoG ONU (65MHz/1610nm RP)
EVCTRL02	MicroNode Controller, 1RU, rear access

Standalone RFoG Architecture with Managed MicroNodes

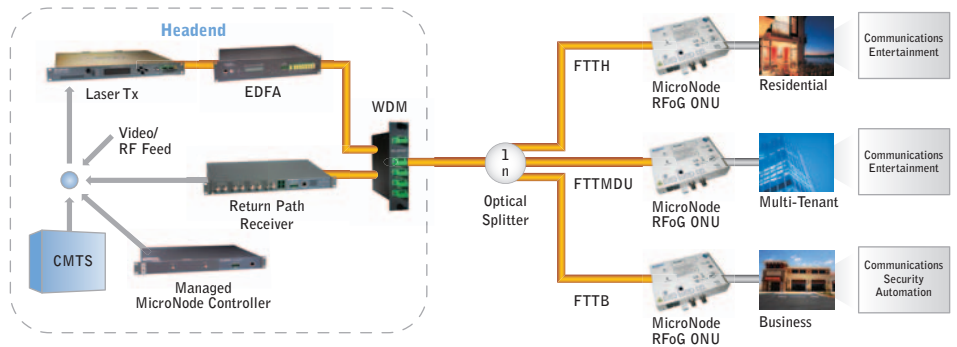

The Managed MicroNode R-ONUs communicate with a central controller, located in the headend or hub, where it receives and transmits the RF communication channel. Each controller unit can manage up to 1024 MicroNode R-ONUs. The controller unit is a 1RU, 19" rack mountable device with browser, telnet or SNMP management interfaces.

Deployments

Managed MicroNode™ R-ONUs can be deployed in any RFoG network. With the same performance and technical characteristics,

there is no reason to adjust a network design based on the type of MicroNode to be used. Any combination of Alloptic MicroNodes can coexist in the same network and on the same PON, allowing great flexibility in how a network operator deploys RFoG: stand-alone unmanaged end points, stand-alone managed end points, hybrid RF PON (PON ONT and R-ONUs deployed together) with managed or unmanaged R-ONUs or any combination of these.



www.alloptic.com

Alloptic, Inc.
2675 Collier Canyon Road
Livermore, CA 94551
925.245.7600